

visionary
DESIGNS™

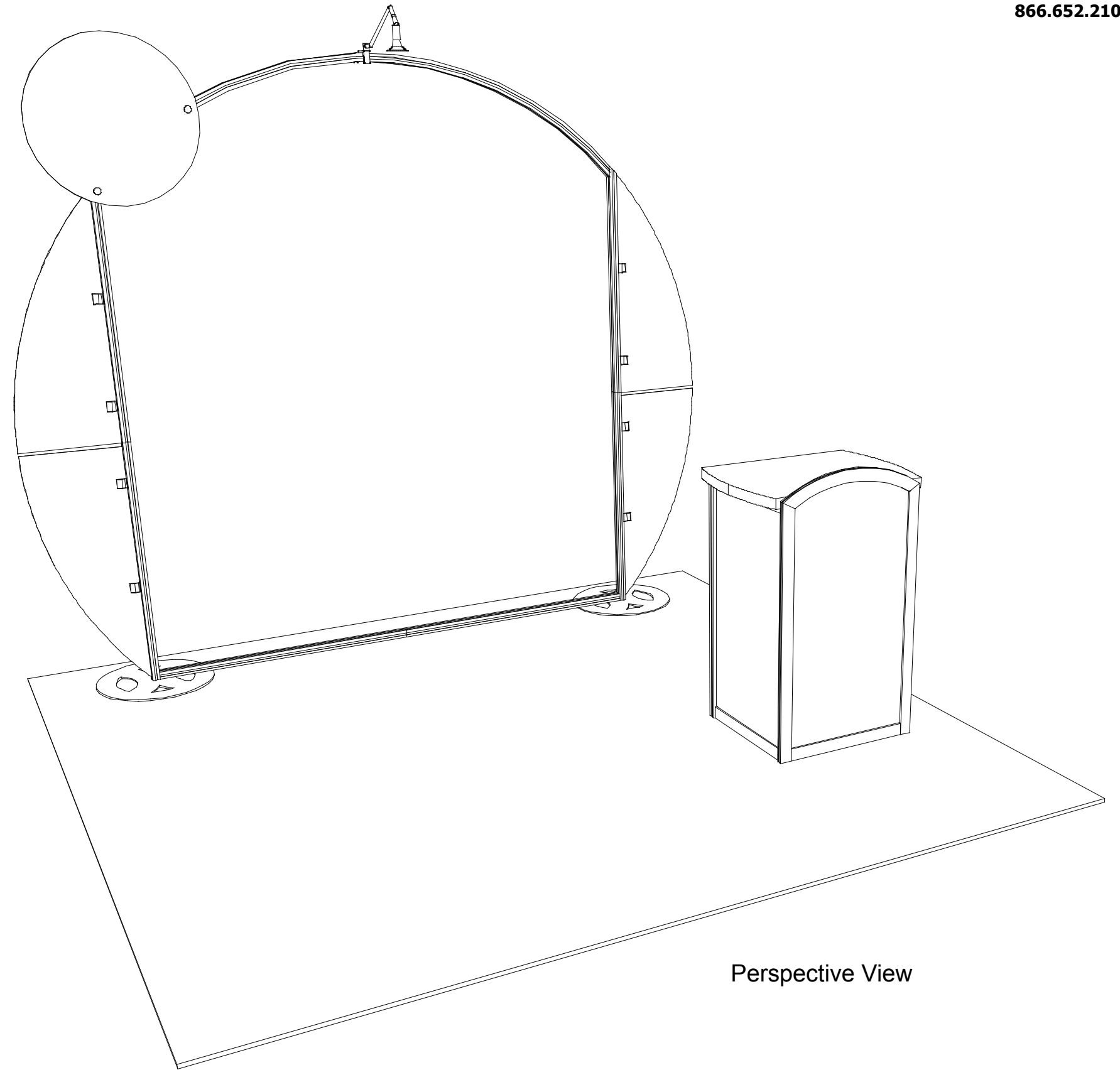
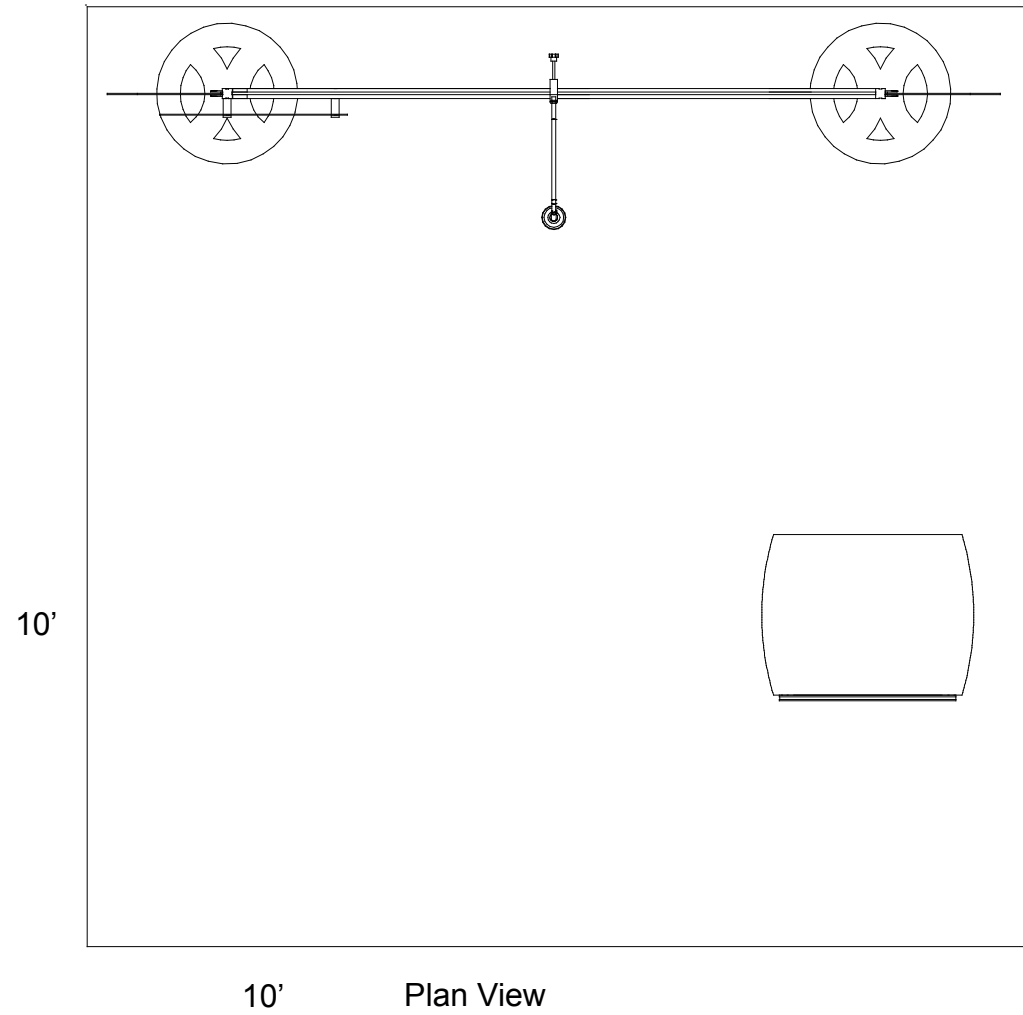

WHEN DISASSEMBLING ALUMINUM EXTRUSION, TIGHTEN ALL SETSCREWS AND LOCKS TO PREVENT LOSS DURING SHIPPING

visionary™ IDESIGNS

Using Your Setup Instructions

The Visionary Designs Setup Instructions are created specifically for your configuration. They are laid out sequentially, including an exploded view of the entire display, and then a logical series of detailed steps to assemble the main structure and components. We encourage you to study the instructions **before** attempting to assemble your exhibit.

Each page reminds you to tighten the setscrews after disassembling your exhibit to prevent loss of the locks and setscrews (see below in RED). This is **VERY IMPORTANT**.

Cleaning and Packing Your Display

- 1) Use care when cleaning aluminum extrusion or acrylic inserts. Use only non-abrasive cleaners.
- 2) When cleaning laminate inserts or countertops, use mild cleansers and a soft material such as cotton.
- 3) Keep all display components away from extreme heat and long exposure to sunlight to avoid warping and fading.
- 4) Retain all packing material. It will make re-packing much easier and will reduce the likelihood of shipping damage.



The Tool

Most Visionary Designs exhibits can be assembled with the supplied Hex Key Tool. Occasionally, a flat head screwdriver may be required.



Detail A

Typical Connection

Most horizontal extrusion connections have a patented expandable lock. This lock inserts into the groove of an opposing extrusion. Tightening the lock with the Hex Key Tool expands the lock and creates a strong positive connection.



Typical Connection (cont'd)

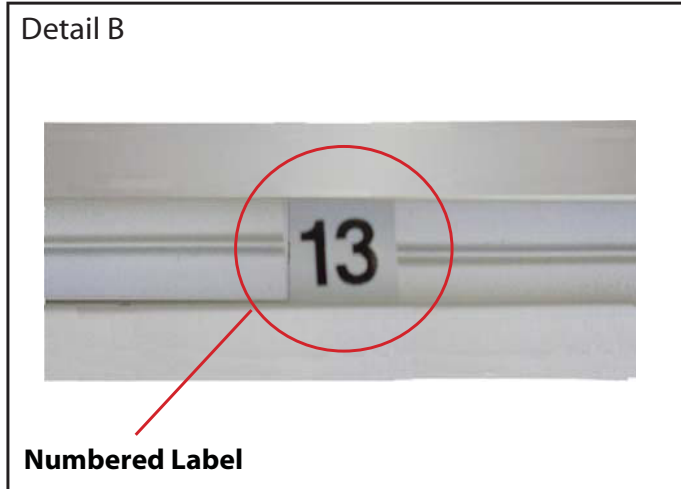

Detail B

Numbered Label

Each extrusion contains a numbered label which corresponds with setup instructions. The label is located within a groove of the extrusion (when possible). With Visionary Designs the labels contain Black numbers unless otherwise specified.



Detail C

Horizontal Inline Connection (remove only one setscrew)

Remove only (1) setscrew when disassembling. Replace setscrew in extrusion after assembling it. Before packing, replace setscrew in extrusion to avoid losing it.

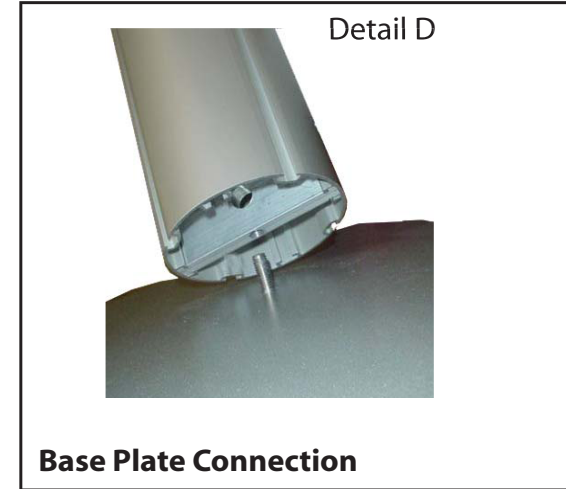

Detail D

Base Plate Connection

Attach base plate to round or square vertical extrusion using the bolt provided. Be careful not to strip the threads.

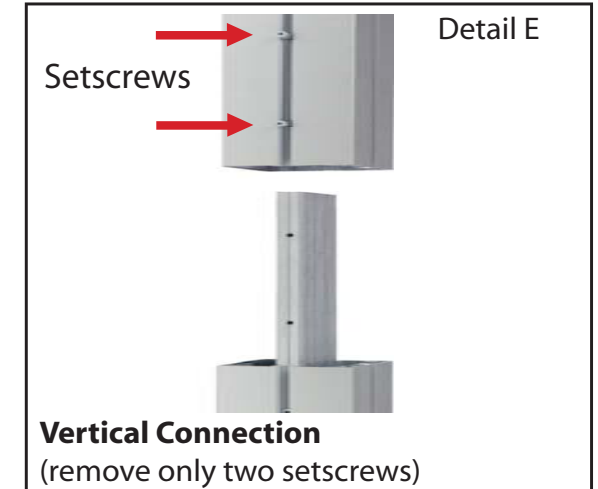

Detail E

Vertical Connection
(remove only two setscrews)

When vertical extrusions are packed in portable cases rather than crates or tubs, they must be broken down into smaller sections which then require assembly.

Remove only (2) setscrews when disassembling. Replace setscrews in extrusion after assembling it. Before packing, replace setscrews in extrusion to avoid losing them.

WHEN DISASSEMBLING ALUMINUM EXTRUSION, TIGHTEN ALL SETSCREWS AND LOCKS TO PREVENT LOSS DURING SHIPPING

866.652.2100

Item	Qty.	Description
1A	2	Base Plates
1	1	39" Vertical extrusion
2	1	39" Vertical extrusion top left outside cut
3	1	39" Vertical extrusion
4	1	39" Vertical extrusion top right outside cut
5	1	41" Horizontal extrusion
6	1	41" Horizontal extrusion
7	1	41" Top left curved extrusion
8	1	41" Top right curved extrusion

- Steps:
- 1) Attach base plates [1A] to lower verticals [1,3].
 - 2) Connect upper verticals [2,4] with connection bars [b].
 - 3) Connect horizontals [5,6] with connection bar [a].
 - 4) Connect vertical [1/2,3/4] with horizontal assembly [5/6].
 - 5) Connect curved extrusions [7,8] with connection bar [a].
 - 6) Connect curved assembly [7/8] between verticals [1/2,3/4].
 - 7) Attach Velcro Graphic to back of frame as shown.

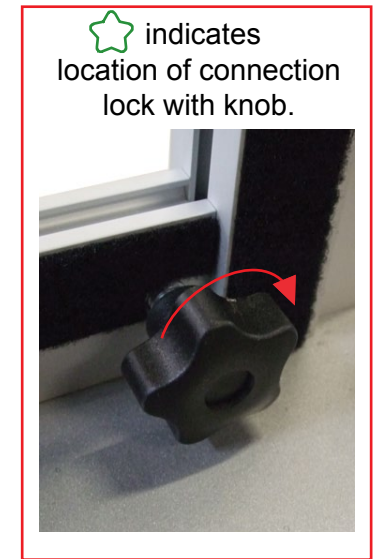
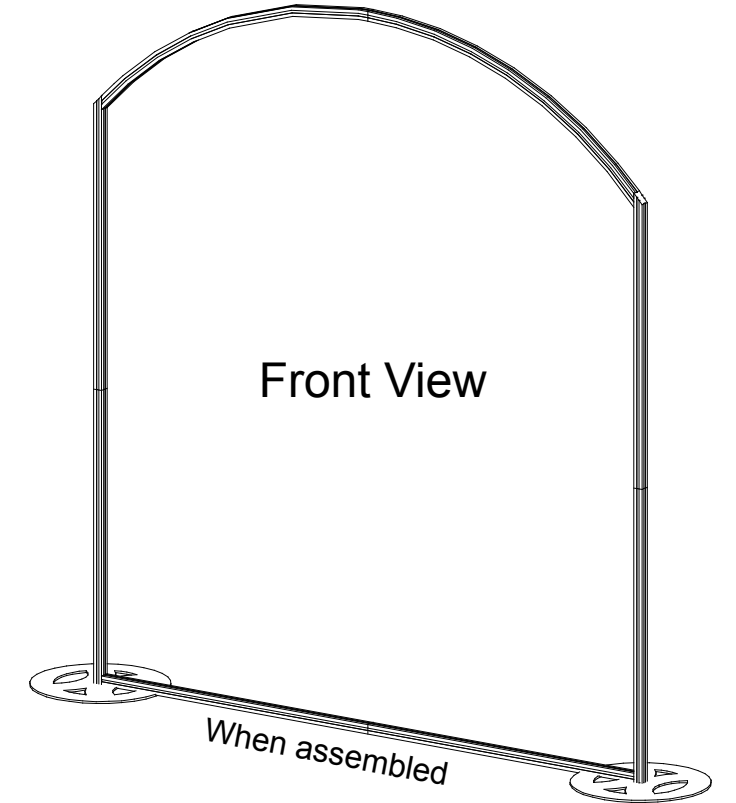
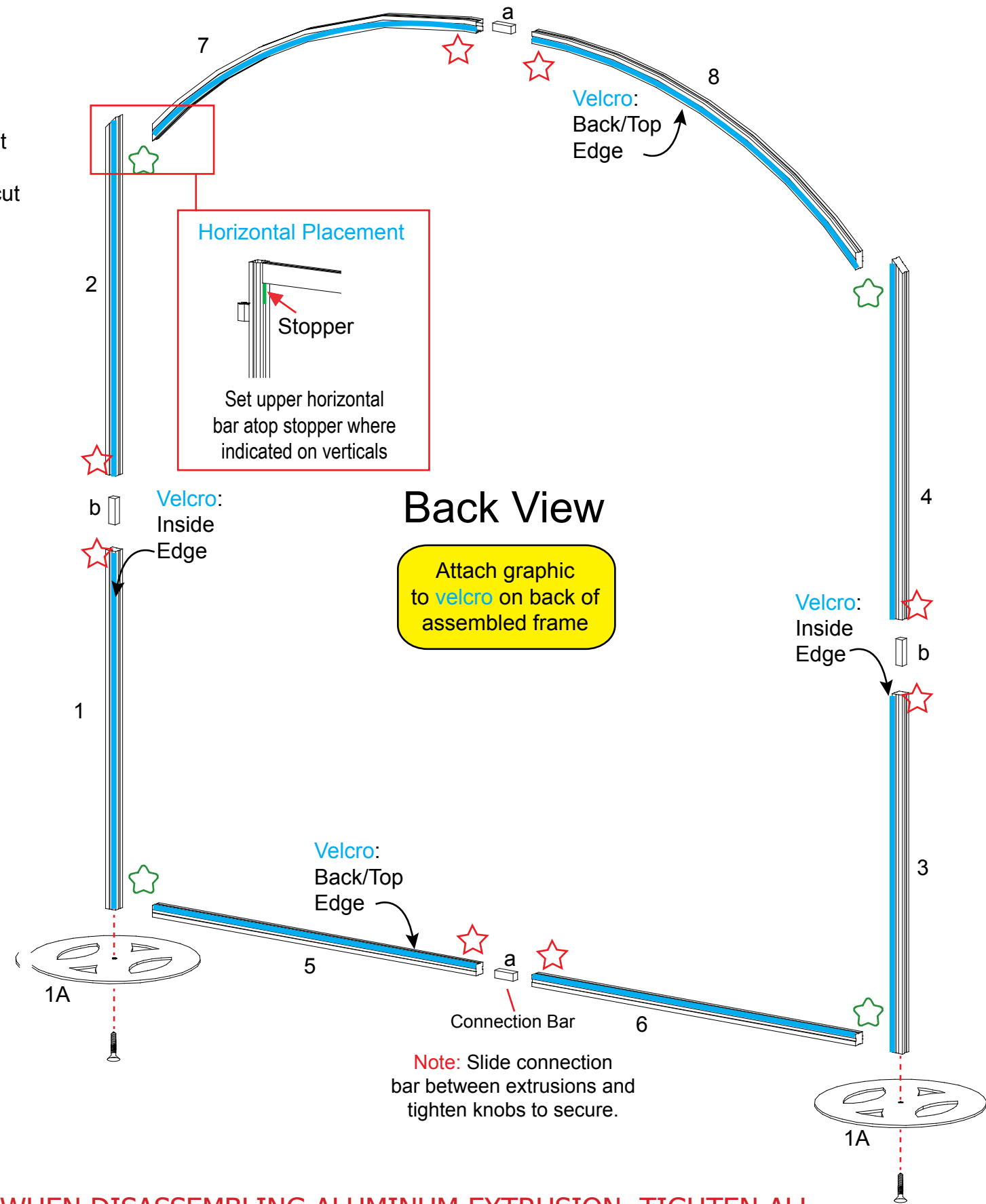
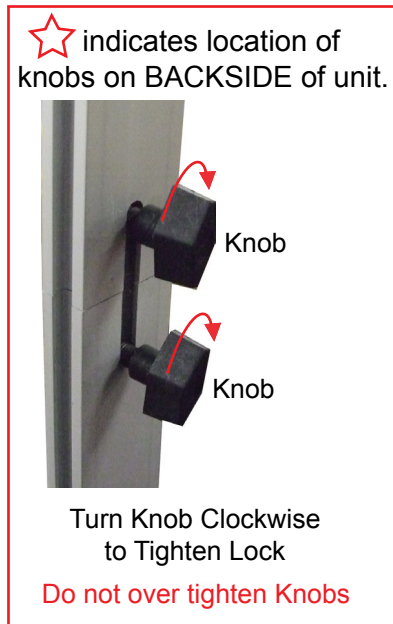

WHEN DISASSEMBLING ALUMINUM EXTRUSION, TIGHTEN ALL SETSCREWS AND LOCKS TO PREVENT LOSS DURING SHIPPING

866.652.2100

Steps:

- 1) Attach A10 Clips and wing graphics as shown in *Wing Attachment* detail.
- 2) Connect stand off barrels to backwall then attach circle graphic as shown in *Graphic Attachment* detail.
- 3) Attach Light atop display as shown in *Light Connection* detail.

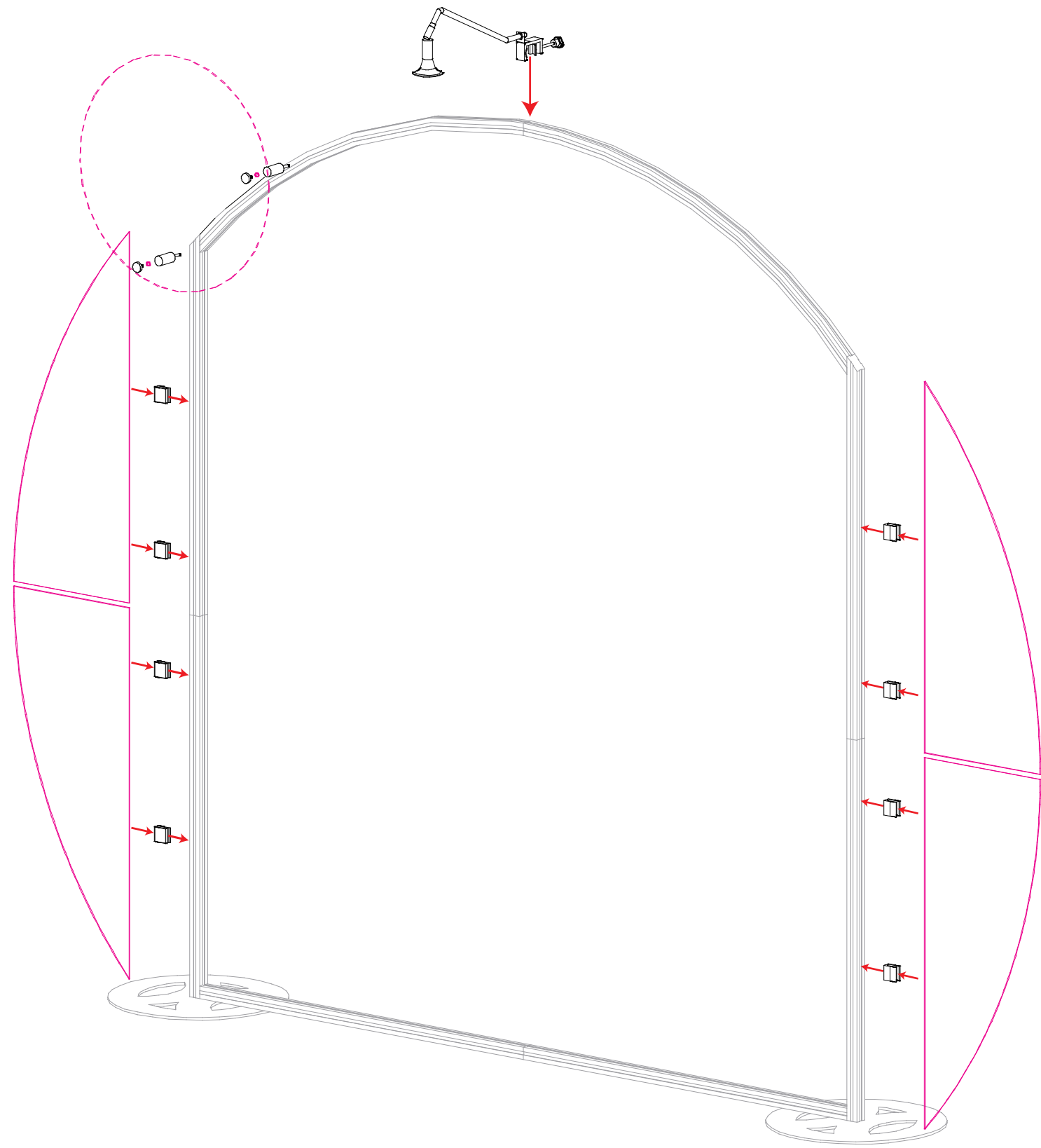
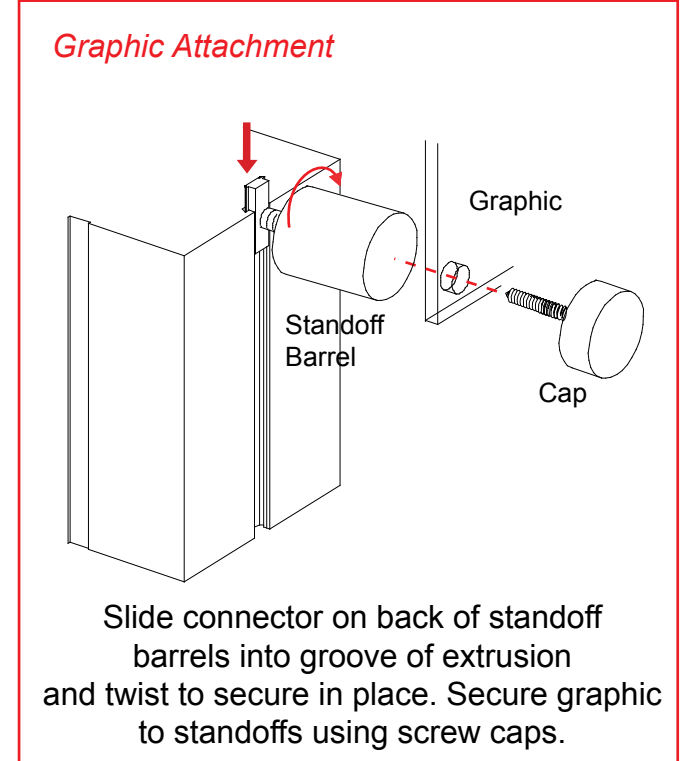
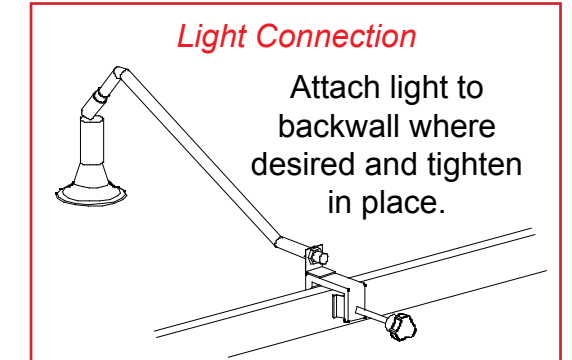
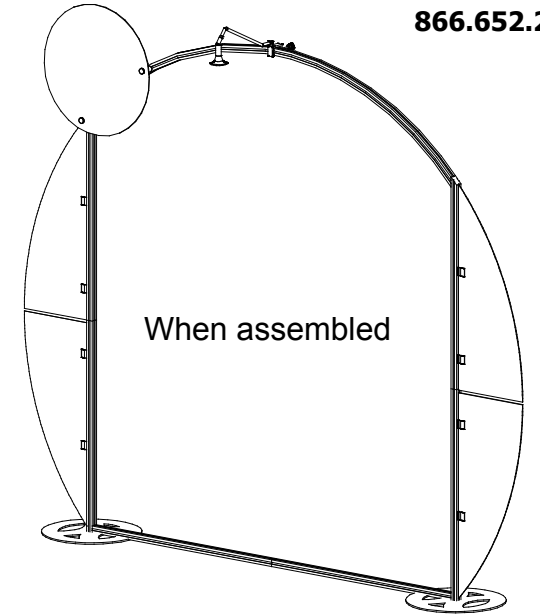

WHEN DISASSEMBLING ALUMINUM EXTRUSION, TIGHTEN ALL SETSCREWS AND LOCKS TO PREVENT LOSS DURING SHIPPING

866.652.2100

Item	Qty.	Description
1-2	1ea.	38" Vertical Extrusion w/ cut
3-4	1ea.	38" Vertical Extrusion
5	1	18.9" Horizontal Extrusion
6-7	1ea.	18" Horizontal Extrusion
8	1	20" Horizontal Extrusion
9	1	22.5" Curved Extrusion
10-11	1ea.	18" Horizontal Extrusion
12	1	20" Horizontal Extrusion

Steps:

- 1) Attach lower horizontals [5,6,7,8] between verticals [1,2,3,4] as shown.
- 2) Attach door using pins as shown in *Door Attachment* detail.
- 3) Insert infills as shown.
- 4) Insert [9,10,11,12] between verticals.
- 5) Place counter on top.

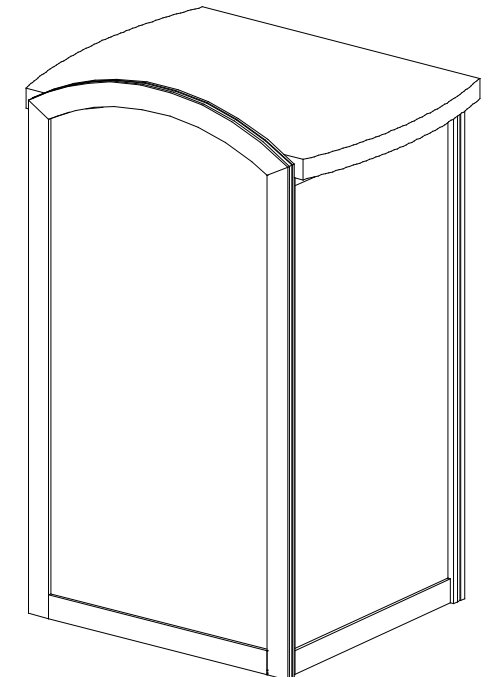
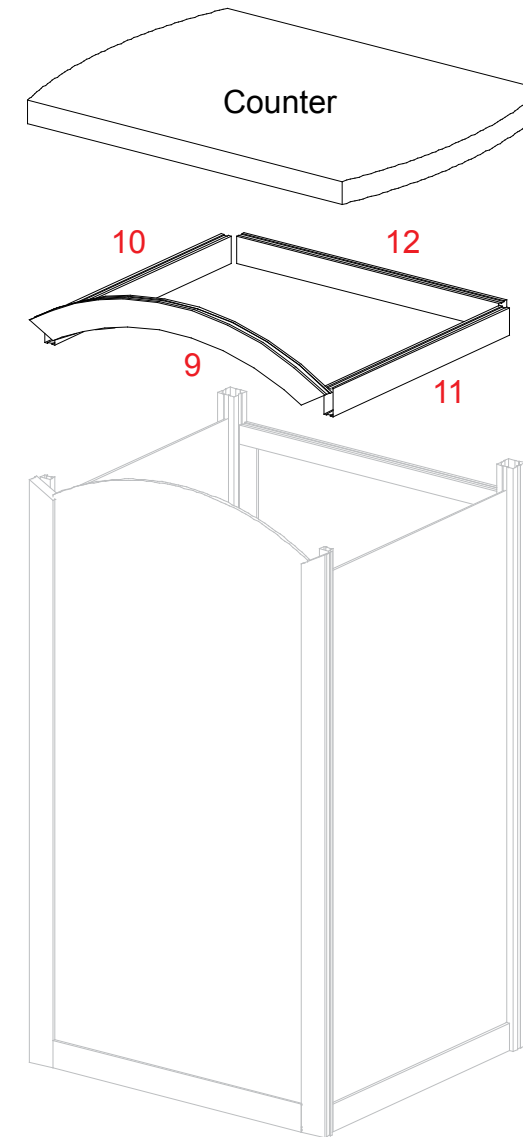
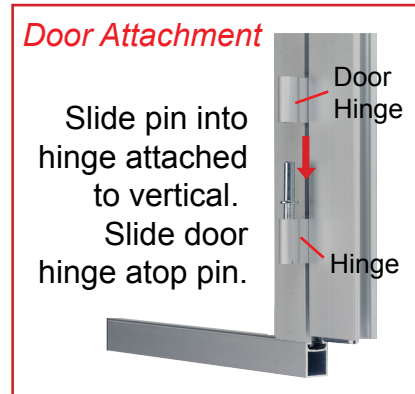
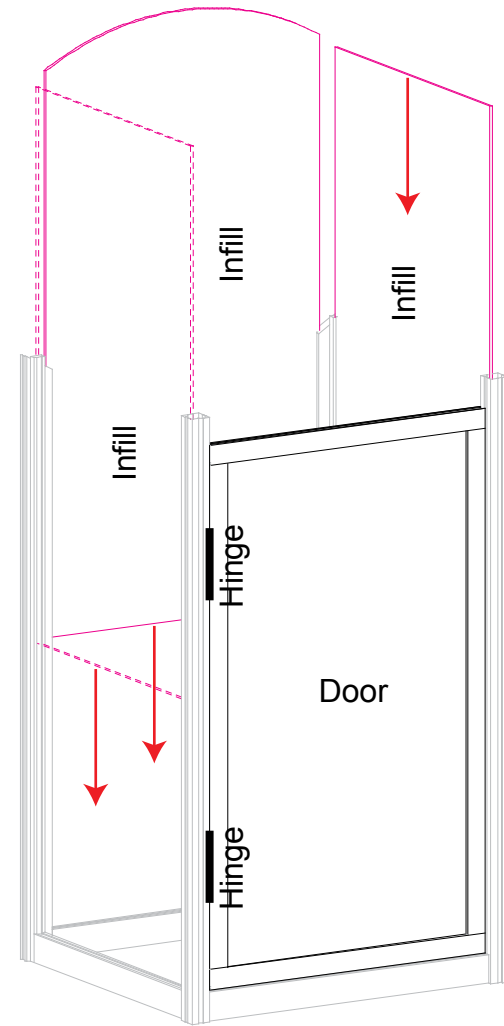
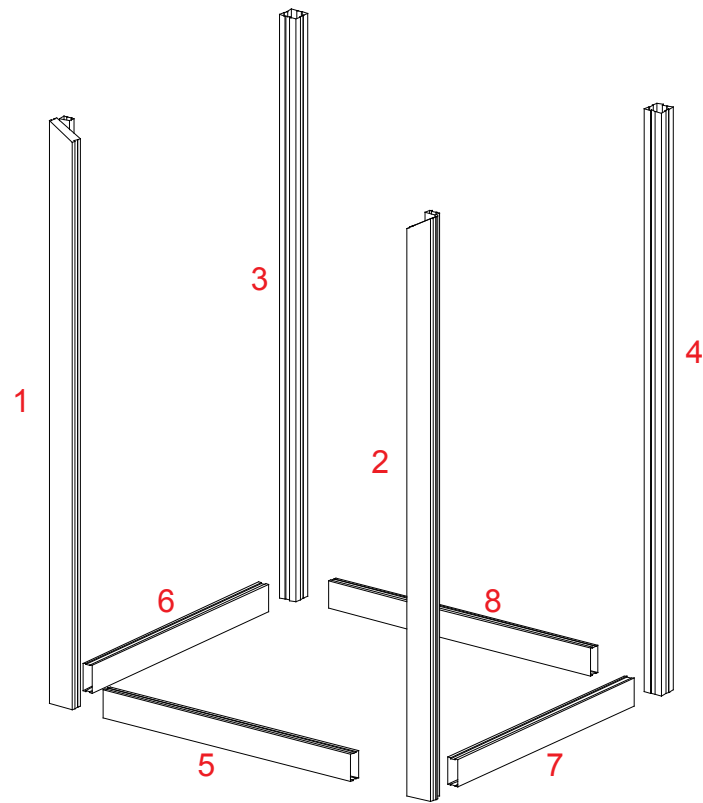

Front Side
When assembled

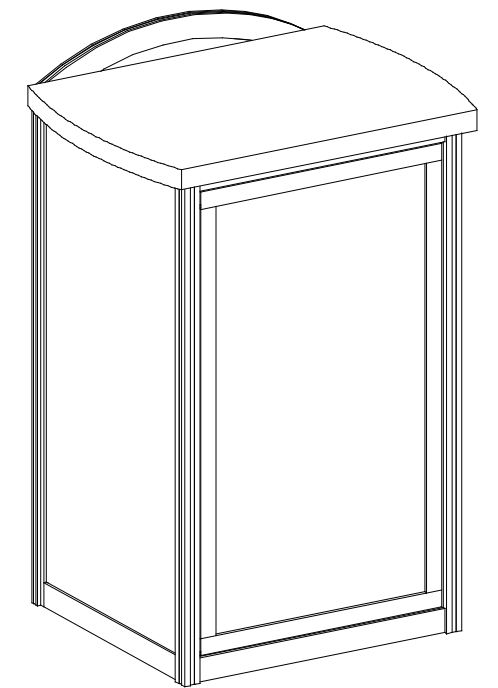

Back Side
When assembled

WHEN DISASSEMBLING ALUMINUM EXTRUSION, TIGHTEN ALL SETSCREWS AND LOCKS TO PREVENT LOSS DURING SHIPPING