

Item	Quantity	Description
1	1	38" RR91 Vertical Extrusion
2	1	38" RR91 Vertical Extrusion
3	1	38" RR91 Vertical Extrusion
4	1	42" RR91 Vertical Extrusion
4A	1	Plate
5,5A	2,2	20" Z45 Horizontal Extrusion
6,6A	2,2	8.5" Z45 Horizontal Extrusion

- Steps:
- 1) Connect horizontals [5] and [6] between verticals [1] [2] [3] and [4], at approximately 4" from floor to bottom of metal. Make sure Velcro is facing inward.
 - 2) Set floor on lip of horizontals [5] and [6]. See **Extrusion Lip** detail.
 - 3) Slide infills between verticals [1] [2] [3] and [4].
 - 4) Connect door between verticals [2] and [3]. See **Door Connection** detail.
 - 5) Place horizontals [5A] and [6A] between verticals [1] [2] [3] and [4], on top of infills and door.
 - 6) Connect **shelf supports** to Velcro onto verticals [1] [2] [3] and [4], then set internal shelf on top of supports.
 - 7) Place counter top onto assembled counter base then secure pins. See **Counter Top Lock** detail.
 - 8) Place shelf onto vertical [4] then secure with wing nuts. See **Shelf Attachment** detail.
 - 9) Attach graphic, using barrels and caps, to verticals [1] and [4]. See **Graphic Attachment** detail.

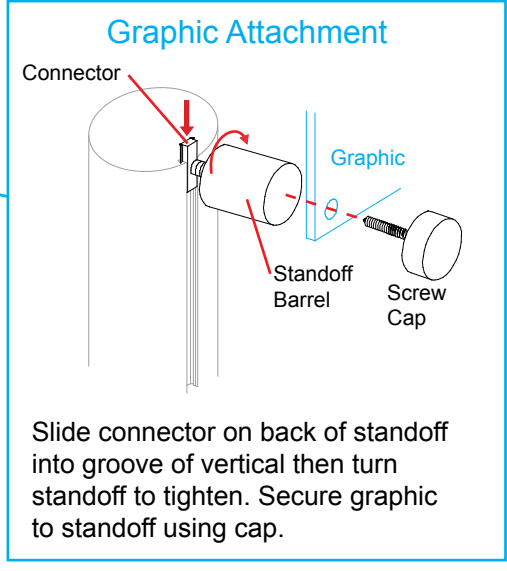
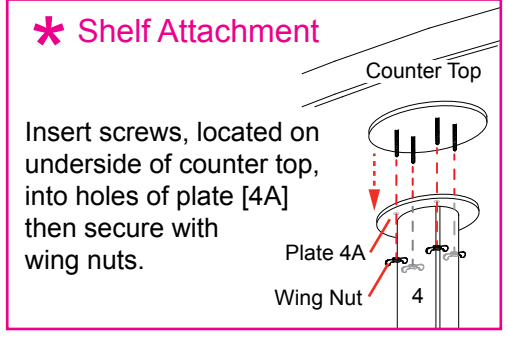
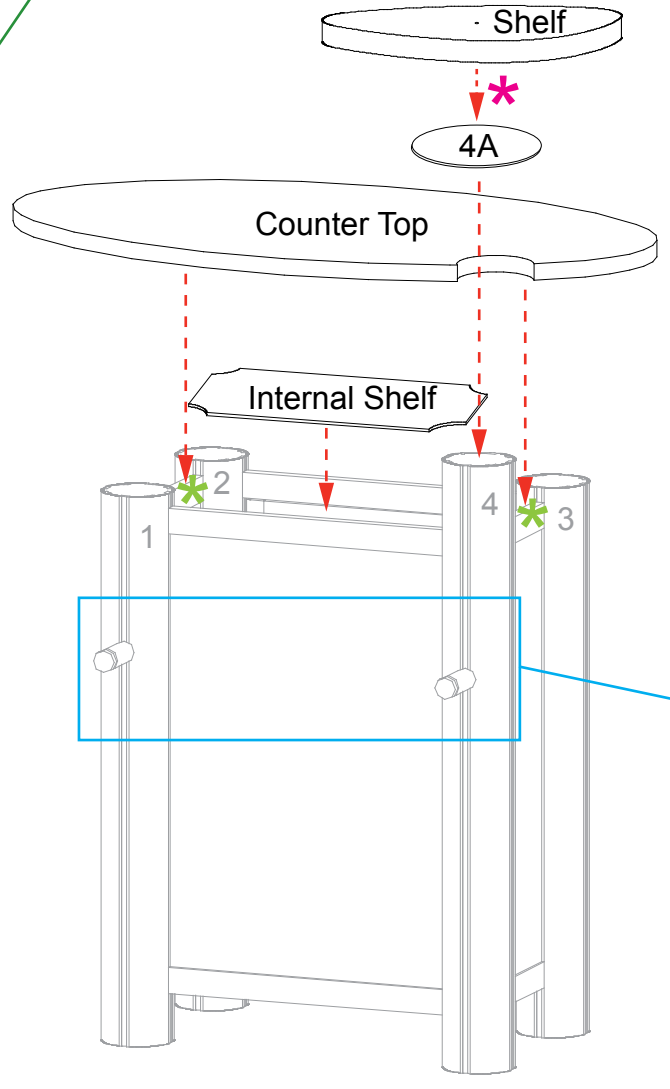
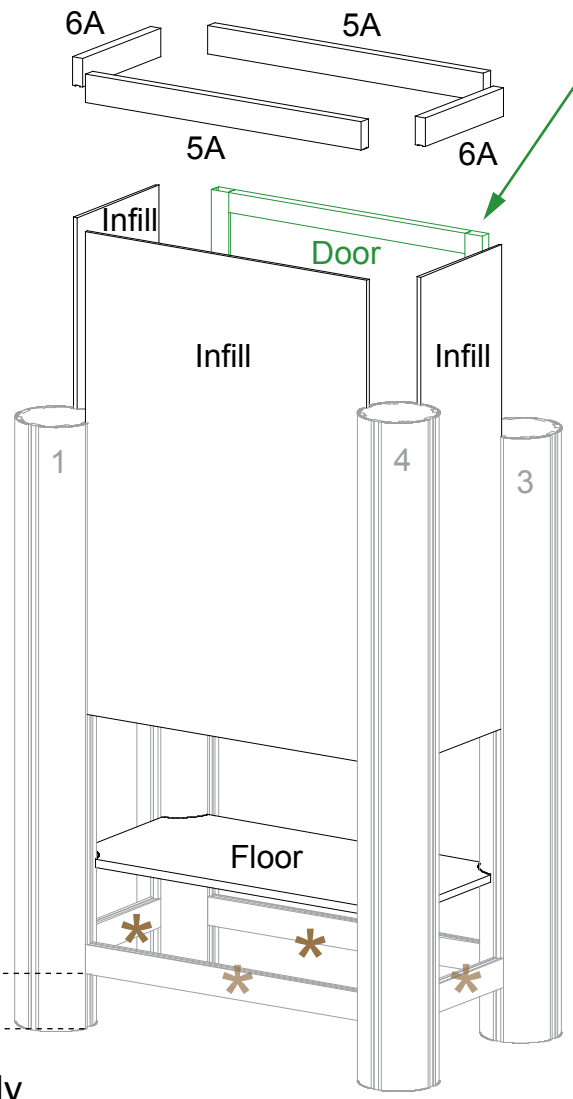
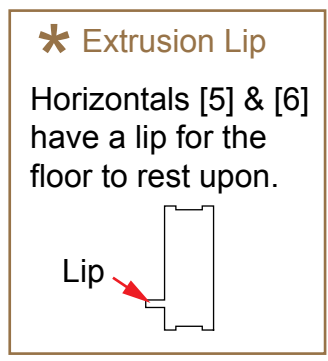
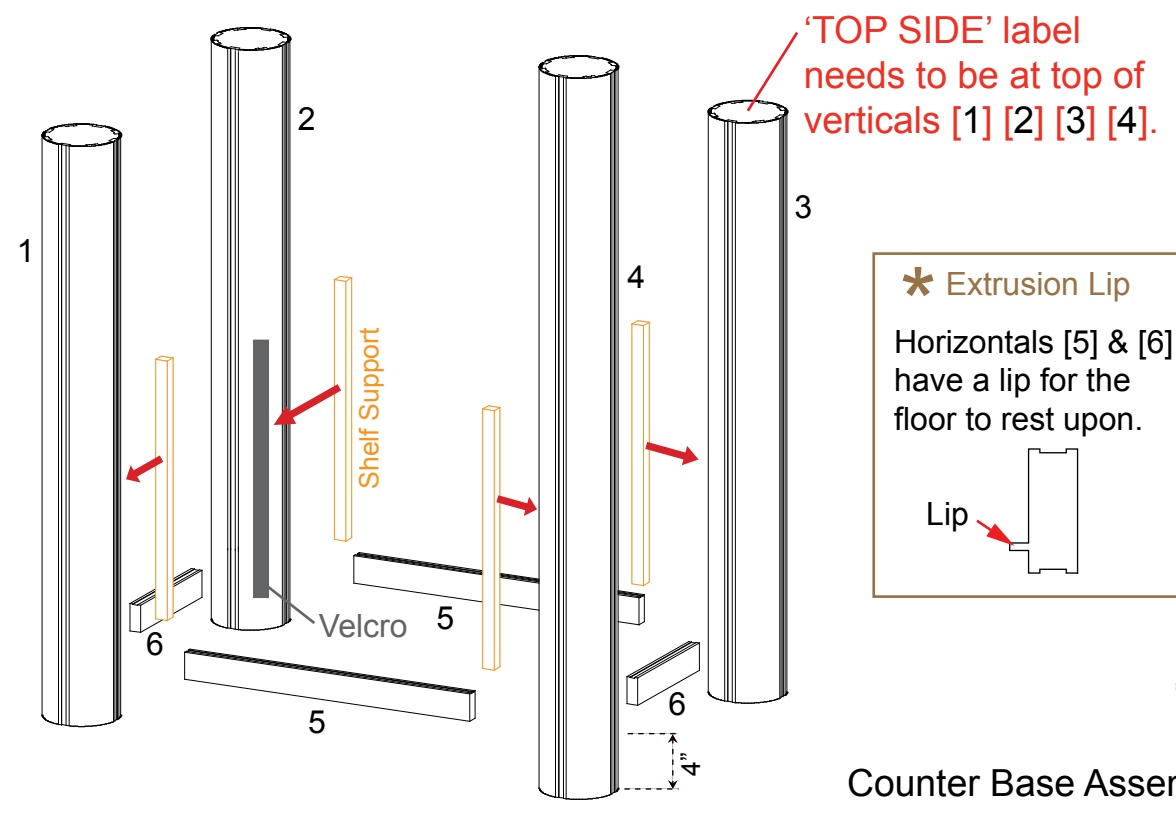
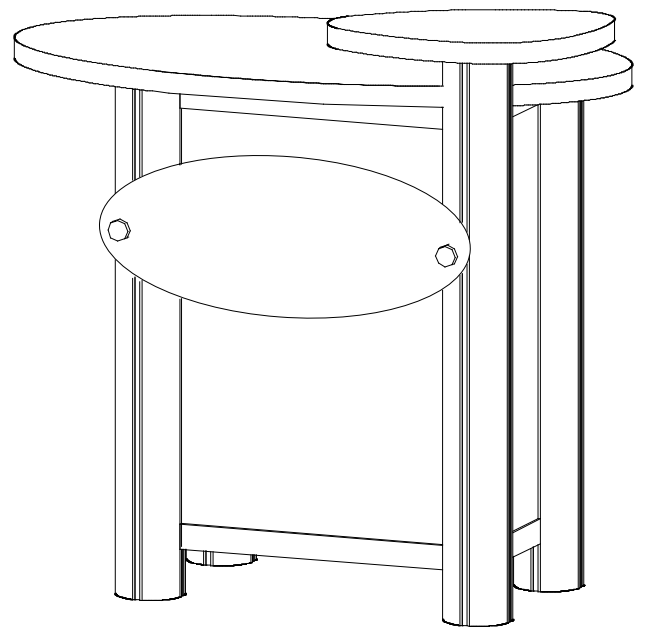
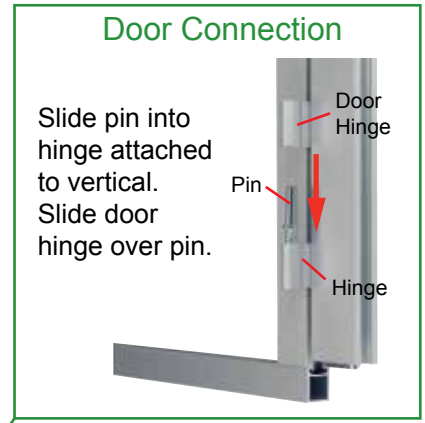
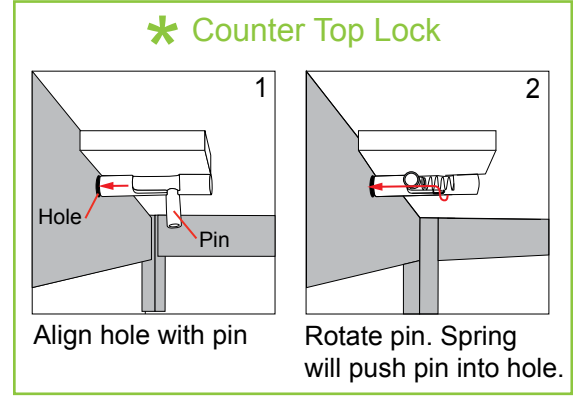

SETUP INSTRUCTIONS

General Setup Instructions

- Read entire setup instruction manual prior to unpacking parts and pieces.
- The setup instructions are created specifically for this configuration.
- Setup instructions are laid out sequentially in steps, including exploded views with detailed explanation for assembly.

Cleaning & Packing

- For Cleaning Metal, Plex, & Laminate Parts: Use a **MILD NON-ABRASIVE** cleanser and soft cloth/paper towel to clean all surfaces.
- Keep exhibit components away from heat and prolonged sun exposure. **Heat and UV exposure will warp and fade components.**
- Retain all provided Packing Materials. All provided packing materials are for ease of repacking & component protection.

Disassembly

- For loss prevention, tighten all set screws and locks during disassembly.

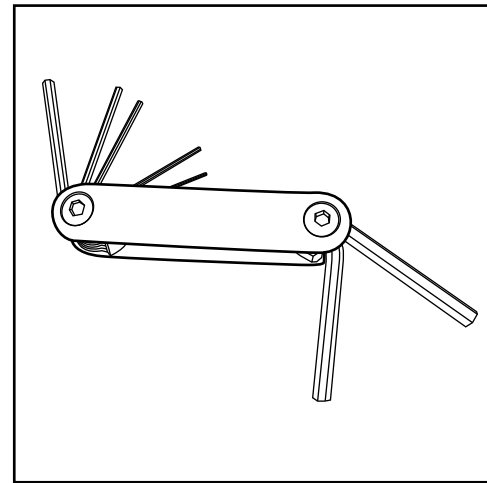

Hex Tool - Essential for Assembly

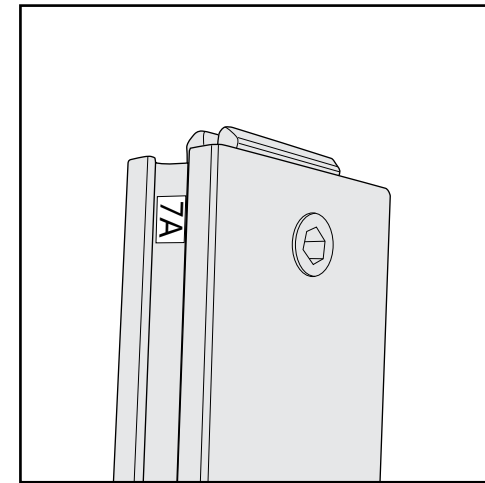

Part Identification - Numbering

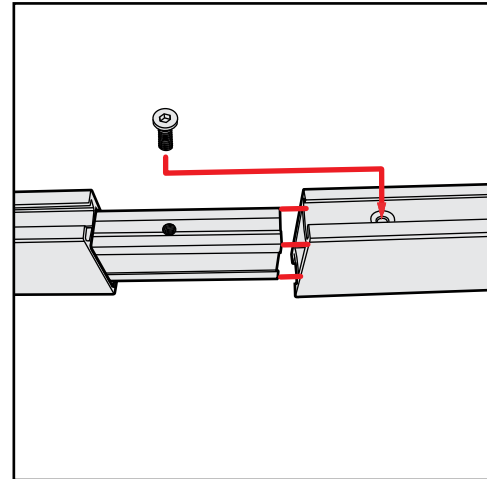

Spline Connection

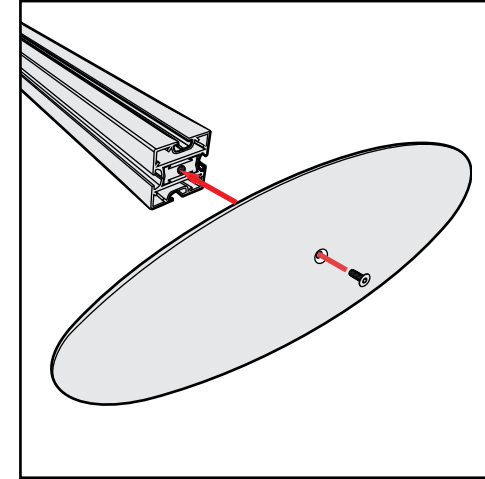

Base Plate & Extrusion Connection

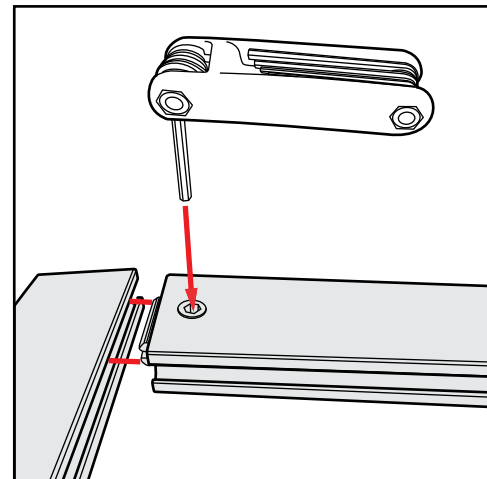

Extrusion & Lock Connection

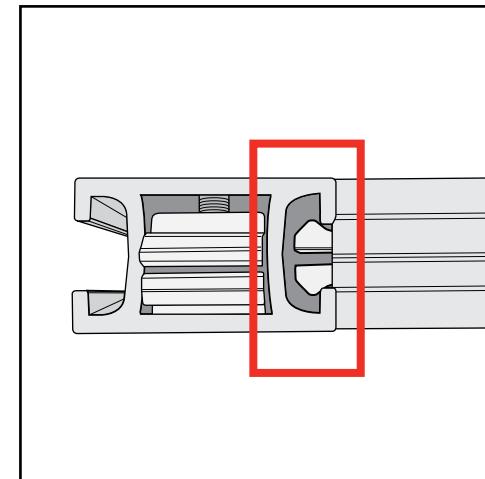

Engaged Lock



WARNING



DO NOT USE POWER TOOLS

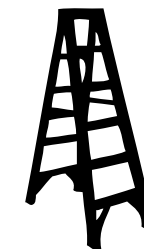

LADDERS OR LIFTS
MAY BE REQUIRED



ALL CONNECTIONS MUST
BE TIGHTLY SECURED

Top View of Each Level

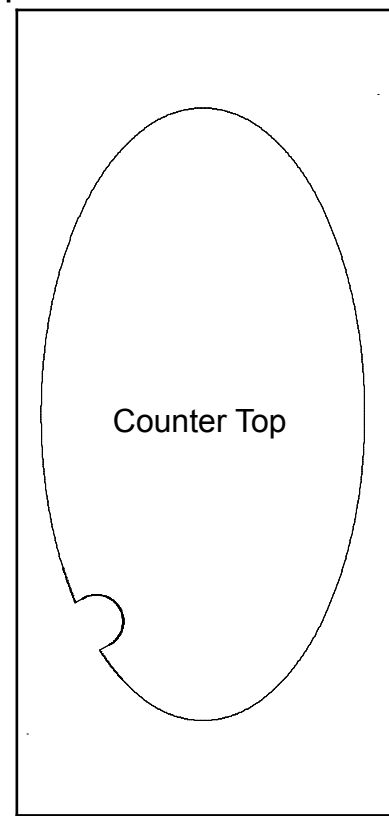

Level 1 (Bottom Level)

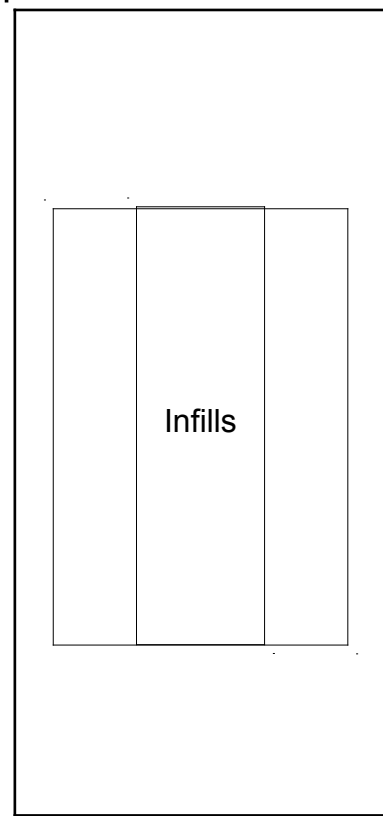

Level 2

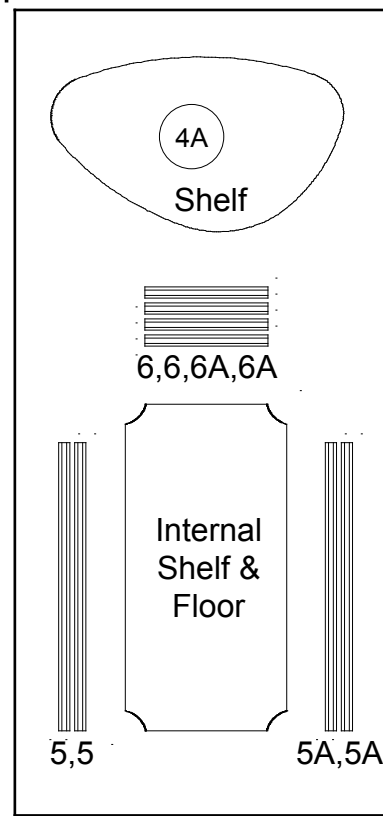

Level 3

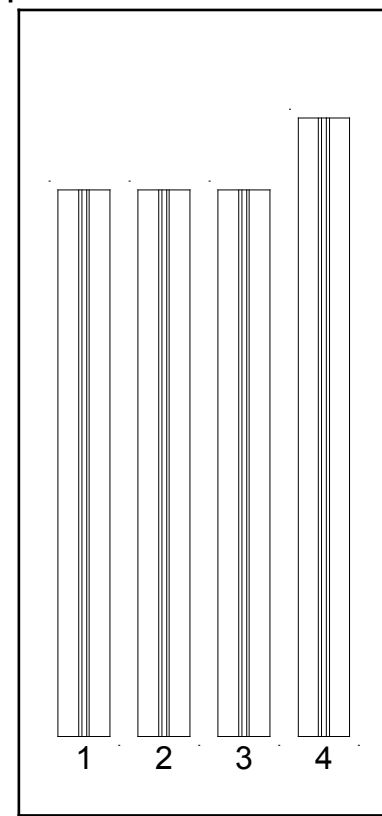

Level 4

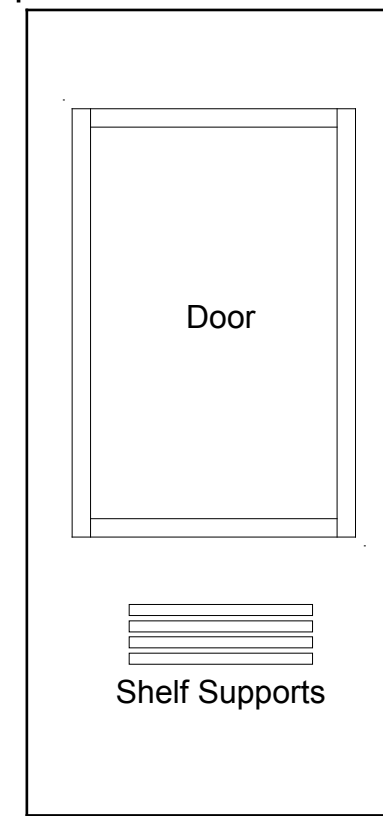

Level 5



Setup Hardware